



# OPERATING INSTRUCTIONS

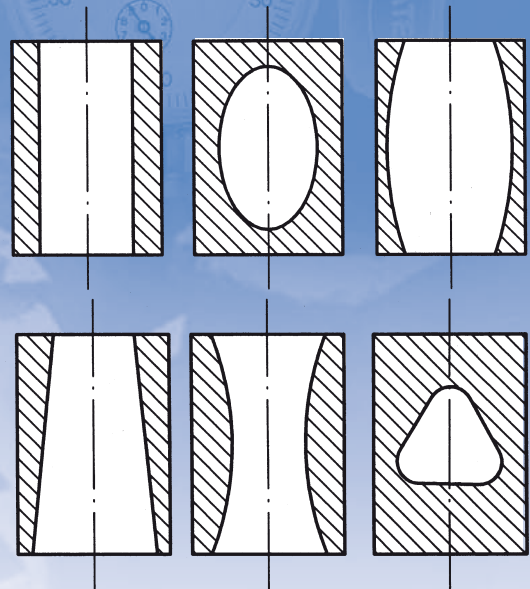
and examples for application

**Jean Louis MENEGON**  
Représentant et Conseiller  
Région Sud Ouest  
Tel : 06 76 08 96 83  
Email: [jlouismenegon@aol.com](mailto:jlouismenegon@aol.com)  
[www.menegon-metrologie.com](http://www.menegon-metrologie.com)



Split-ball probes  
Floating holders  
Checking stands  
Accessories

Precision bore gauges  
range 0.47 – 41.1 mm  
0.0185" – 1.62"



Please read carefully and keep it.  
It is worthwhile.



**Jean-Louis MENEGON** - Représentant & conseiller Sud Ouest

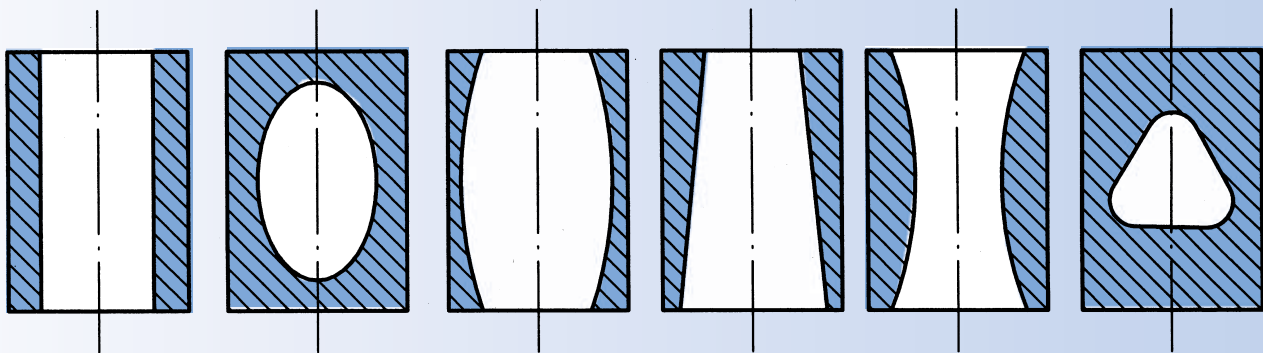
tél: 06.76.08.96.83 - mail: [jlouismenegon@aol.com](mailto:jlouismenegon@aol.com) - site web: [www.menegon-metrologie.com](http://www.menegon-metrologie.com)

DIATEST split-ball probes are comparative gauges for detecting size deviations and shape defects of bores (see pictures below).

The modular design of DIATEST-gauges facilitates the measuring of most common bores. This allows the use of the bore gauges for series production and individual control of bores in the calibration laboratory, in the vendor inspection department and specially in production directly at the machine.

Numerous accessories permit the utilization of the gauges for manual gauging, the use of checking stands and the installation in fixtures as well.

More than fifty years of experience in the bore gauge production and the research for technical improvement and of course an excellent customer service are the base for the well-known quality of DIATEST-gauges.



Safety through quality

**Jean-Louis MENEGON**

Représentant & conseiller Sud Ouest

tél: 06.76.08.96.83 - mail: [jlouismenegon@aol.com](mailto:jlouismenegon@aol.com) - site web: [www.menegon-metrologie.com](http://www.menegon-metrologie.com)

---

**TABLE OF CONTENTS**

---

Page

**Split-ball gauges**

- 4-5** Principle of measuring, assembly, centering errors
- 4-5** Zero-setting, measuring
- 8** Measuring accuracy
- 9** Hardness of wear points, life
- 10-11** Maintenance, repair of probes
- 16-18** Range, technical data

**Setting rings**

- 6-7** Style and accuracy
- 6-7** Technical data, nominal sizes
- 6** Additional setting means

**Indicators**

- 9** Selection, clamping stem
- 17-18** Measuring pressure (recommended)

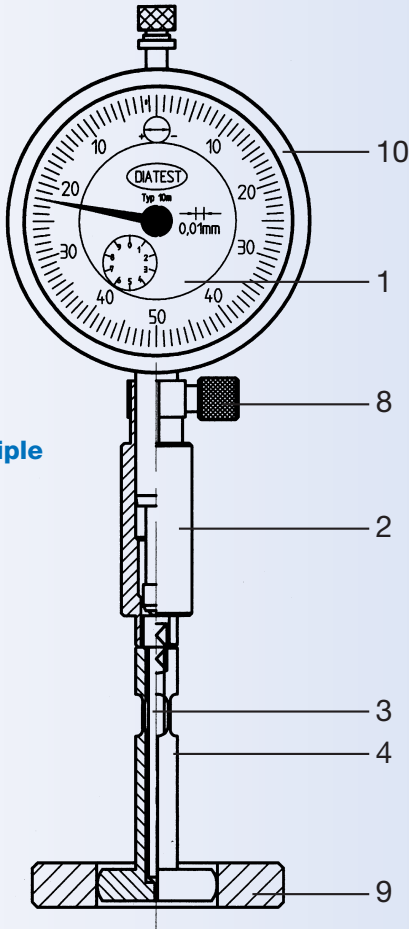
**DIATEST system elements**

- 12-13** Standard-, flat-bottom-, HM-split-ball probes
- 14** T-split-ball probes
- 14** Right angle attachment, depth stops
- 15** 3-point and gun barrel probes
- 15** Rotary adaptor
- 19-21** Checking stands and attachments (MST-58)
- 22-24** Universal stand and attachments (MST-102)
- 24-26** Floating holder and attachments (SH-T)

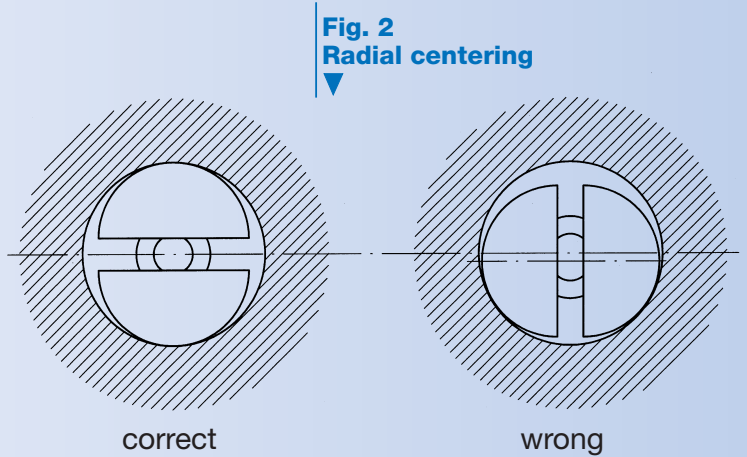
**26-27 Finally some advice****Jean-Louis MENEGON**

Représentant &amp; conseiller Sud Ouest

tél: 06.76.08.96.83 - mail: [jlouismenegon@aol.com](mailto:jlouismenegon@aol.com) - site web: [www.menegon-metrologie.com](http://www.menegon-metrologie.com)



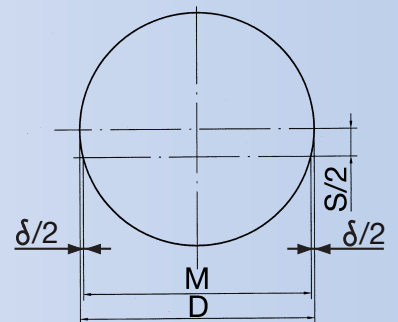
**Fig. 1**  
Split-ball principle  
of measuring



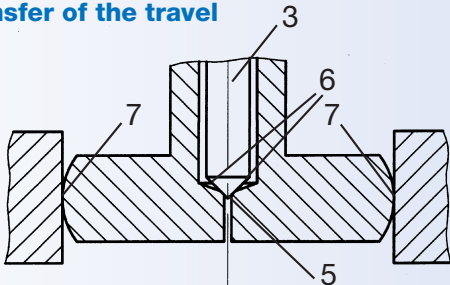
**Fig. 2**  
Radial centering

$$\delta = \frac{S^2}{2 \cdot D}$$

**Fig. 3**  
Radial centering  
error

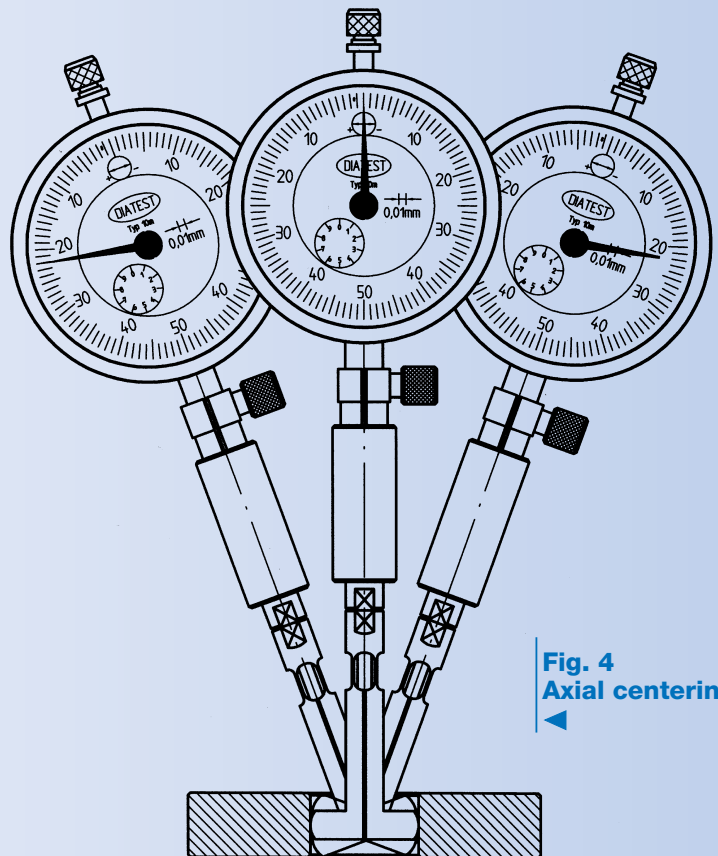
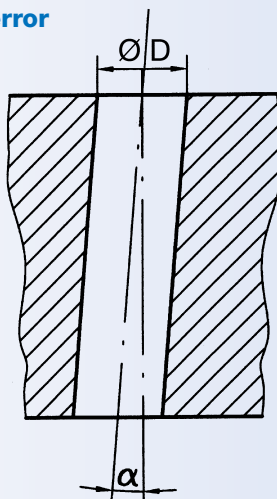


**Fig. 1a**  
Transfer of the travel



**Fig. 5**  
Axial centering error

$$\delta = \frac{D}{\cos \alpha} - D$$



**Fig. 4**  
Axial centering

**Jean-Louis MENEGON**

Représentant & conseiller Sud Ouest

## ASSEMBLY / PRINCIPLE OF MEASURING / CENTERING ERRORS / ZERO-SETTING / MEASURING

### Assembly (Fig. 1)

The split-ball probe (4) with needle (3) is screwed in the handle (2) and slightly tightened with a wrench. The indicator (1) is fixed in the clamp of the holder  $\varnothing 8$  H7 (3/8" H7) and tightened with a knurled screw (8).

### Transfer of the travel (Fig. 1a)

The lapped taper (5) of the needle (3) is located at the edges (6) of the split-ball probe and transfers the travel of the two contacts (7) in a 1:1 ratio to the indicator (1).

### Radial centering (Fig. 1 and 2)

**Important:** The bore diameter must be detected concentric to the bore!  
The spring force of the indicator spreads the two semicircular contact points via the tapered needle and helps the gauge to center.

### Radial centering errors (Fig. 2 and 3)

Avoid a lateral force of the split-ball probe during the measurement in the bore. If the gauge is not served to center, the maximum bore diameter is not detected but a smaller chord.

### Very important

**When measuring horizontally with split-ball probes use the gauges as shown in Fig. 2. The contacts must be vertical, that means the slot must be horizontal.**

### Axial centering (Fig. 4)

**Important:** The bore diameter has to be detected vertically to the axis of the bore. When gauging by hand the axial centering

is made by oscillating the bore gauge through the vertical axis of the bore (Fig. 4).

The reversal point of indicator hand shows the vertical axis of the bore. In practice this is generally not significant.

### Zero-setting of split-ball probes (Fig. 1)

After introducing the split-ball probe in a setting master (9) you can find the reversal point of indicator hand by oscillating (Fig. 4). Then set the indicator to zero by adjusting the indicator in the clamp of the holder or by turning the bezel of indicator (10).

### Measuring

Introduce the gauge in the bore. Oscillate as shown in Fig. 4. The reversal point of indicator hand shows the deviation of the bore corresponding to the setting master:

- Bore diameter is bigger: indicator hand is on the left hand side of zero-marking.
- Bore diameter is smaller: indicator hand is on the right hand side of zero-marking.

### Axial centering error (Fig. 5)

When measuring with a stand (page 19) or depth-stop (page 12) bores with an angle less or more than 90 degrees (see Fig. 5) could cause minor problems. In practice this is not significant in most cases.

### Example

Work piece outside dimensions:

100 x 100 x 100 mm

Error in angle =  $30'$  = 0.87 mm slant in bore

The theoretical error is for bore diameter  $\varnothing 1$  mm 0,04  $\mu\text{m}$ ,  $\varnothing 5$  mm 0,2  $\mu\text{m}$ ,  $\varnothing 20$  mm 0,8  $\mu\text{m}$ .

Since the contacts are spherical these errors are even considerably smaller.

**Jean-Louis MENEGON**

Représentant & conseiller Sud Ouest

tél: 06.76.08.96.83 - mail: [jlouismenegon@aol.com](mailto:jlouismenegon@aol.com) - site web: [www.menegon-metrologie.com](http://www.menegon-metrologie.com)

## SETTING RINGS / STYLE AND ACCURACY / ADDITIONAL SETTING MEANS

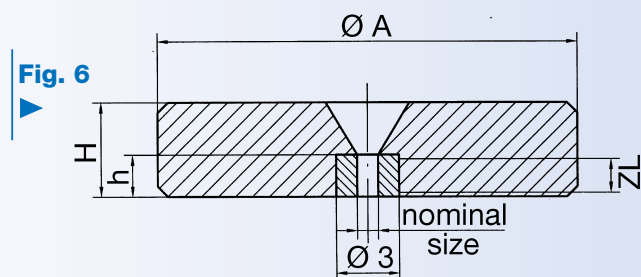
### Setting means

It is recommended to zero-set a split-ball probe with a setting master. This is the fastest and safest method since the test object (bore) and the setting means are equal in shape.

### DIATEST-Setting rings

(see table on page 7)

are produced in metric and in inch style without deviation engraved since this may easily lead to setting errors because of mistaking of plus- and minus-deviations.



**Setting rings 0.500 to 1.500 mm insert  
made of synthetic sapphire**

### Design of the DIATEST-Setting rings

#### Nominal sizes 0.500 - 1.500

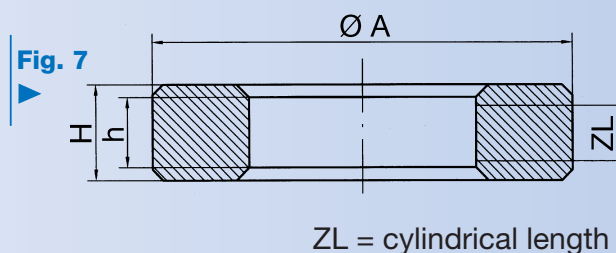
(0.0200" - 0.0600")

Ring mounting made of steel, black finished. Insert made of synthetic sapphire. Bore finely lapped.

#### Nominal sizes 1.750 - 40.000

(0.0625" - 1.5800")

Made of wear resisting special steel, black finished. Bore finely lapped. Rings are artificially aged and thus particularly permanent to size.



**Setting rings 1.750 to 40.000 mm made  
of special steel, artificially aged**

size	00	0	1	2	3	4	5
Ø A	20	20	20	20	36	45	60
H	4,5	4,5	4,5	4,5	7,5	10	12
h	2	3	4	4	7	9	11
ZL	1,7	2,7	3,5	3,5	6	8	10

Additional setting means for split-ball probes:  
Slip gauges, snap gauges: Well suited for zero-setting in stationary gauging. Micrometer for secondary measuring jobs.

**Jean-Louis MENEGON**

Représentant & conseiller Sud Ouest

tél: 06.76.08.96.83 - mail: [jlouismenegon@aol.com](mailto:jlouismenegon@aol.com) - site web: [www.menegon-metrologie.com](http://www.menegon-metrologie.com)

**SETTING RINGS / STYLE AND ACCURACY**

Dimen. Size	Nom. Size	Nom. Size	inch Size	Dimen. Size	Nom. Size	Nom. Size	inch Size	
	metric	inch	mm		metric	inch	mm	
00	R - 0.500	0.0200	0.508	3	R - 10.000	0.4000	10.160	
	R - 0.550	0.0220	0.559		R - 11.000			
	R - 0.600	0.0250	0.635		R - 11.500	0.4500	11.430	
	R - 0.700	0.0280	0.711		R - 12.000			
	R - 0.800	0.0320	0.813		R - 13.000	0.5000	12.700	
	R - 0.900	0.0360	0.914		R - 14.000	0.5500	13.970	
0	R - 1.000	0.0400	1.016		R - 15.000	0.6000	15.240	
	R - 1.100	0.0450	1.143		R - 16.000			
	R - 1.200	0.0500	1.270		R - 16.500	0.6500	16.510	
	R - 1.300	0.0550	1.397		R - 17.000			
	R - 1.400				R - 18.000	0.7000	17.780	
	R - 1.500	0.0600	1.524		R - 19.000	0.7500	19.050	
1	R - 1.750	0.0625	1.587		4	R - 20.000	0.8000	20.320
	R - 2.000	0.0750	1.905			R - 21.000	0.8500	21.590
	R - 2.250	0.0875	2.222			R - 21.500		
	R - 2.500	0.1000	2.540			R - 22.000		
	R - 2.750					R - 23.000	0.9000	22.860
	R - 3.000	0.1150	2.921			R - 24.000	0.9500	24.130
	R - 3.250	0.1300	3.302	R - 25.000				
	R - 3.500			R - 25.500		1.0000	25.400	
R - 3.750	0.1450	3.683	R - 26.500					
2	R - 4.000	0.1600	4.064	5		R - 27.000	1.0500	26.670
	R - 4.500	0.1800	4.572		R - 28.000	1.1000	27.940	
	R - 5.000	0.2000	5.080		R - 29.000			
	R - 5.500				R - 30.000	1.1800	29.972	
	R - 5.750	0.2250	5.715		R - 31.000			
	R - 6.000				R - 32.000	1.2600	32.004	
	R - 6.500	0.2500	6.350		R - 33.000			
	R - 7.000	0.2750	6.985		R - 34.000	1.3400	34.036	
	R - 7.500				R - 35.000			
	R - 7.750	0.3000	7.620		R - 36.000	1.4200	36.068	
	R - 8.000	0.3250	8.255	R - 37.000				
	R - 8.500			R - 38.000	1.5000	38.100		
R - 9.000	0.3500	8.890	R - 39.000					
R - 9.500	0.3750	9.525	R - 40.000	1.5800	40.132			

Also available: DIATEST-Setting rings with Ø 10.5 / 11.5 / 12.5 to 29.5

**Accuracy of DIATEST-Setting rings**

	0.500 - 1.500	1.750-40.000
Max. deviation from nominal size	1 µm	0.9 µm
Max. roundness error	0.4 µm	0.3 µm
Max. surface roughness	0.03 µm	0.02 µm
Hardness	2000 Knoop	62-64 HRC

**Jean-Louis MENEGON**

Représentant &amp; conseiller Sud Ouest

tél: 06.76.08.96.83 - mail: [jlouismenegon@aol.com](mailto:jlouismenegon@aol.com) - site web: [www.menegon-metrologie.com](http://www.menegon-metrologie.com)

## MEASURING ACCURACY / INDICATORS / HARDNESS OF WEAR POINTS / LIFE

**The measuring accuracy depends on different factors such as:**

### 1. Setting means

The dimensional error of the setting means has to be taken into consideration like for all comparative gauges.

### 2. Repeatability (standard split-ball probes)

- a) Manual gauging: c. 1  $\mu\text{m}$
- b) Stationary gauging with floating holder: c. 0.5  $\mu\text{m}$

### 3. Travel error (standard split-ball probes)

Each gauging transmission involves errors. Travel errors of DIATEST split-ball probes are as follows:

- Size 0.50 - 1.50 = max. 2 % of the travel
- Size 1.75 - 40.0 = max. 1 % of the travel

#### Example

Probe T-6.0, setting ring R-6.000, bore size = 6.1 mm = max. travel error 1 % = 1  $\mu\text{m}$ .

#### Important

**For exact bore gauging, bore and setting size should coincide. Possibly use special rings (on request).**

### 4. Influence of temperature

DIATEST split-ball probes are largely insensitive to normal variations in temperature due to their construction.

### 5. Selection of indicators, micro comparators, electronic bore gauges

The selection of the indicating unit depends on the precision requirements.

For normal use in the workshop an indicator 0.01 mm (e.g. DIATEST dial indicator MU-10m) is sufficient. In case of high demands as to the measuring accuracy mechanical micro comparators (F 1000, DM 1003 or MU-1m), torsional-micro comparators (Mikrocator) or electronic probes (e.g. DIATEST MTD) can be used.

#### Important

**Pay attention to the measuring pressure of the indicating device (see table on page 16/17)**



## MEASURING ACCURACY / INDICATORS / HARDNESS OF WEAR POINTS / LIFE

### Clamping shank of indicating units

(see illustration)

As special accessory an indicator holder with bore  $\varnothing 3/8'' = 9.525 \text{ mm}$  can be supplied (e.g. MH-6-51-Z)

### Hardness of wearing points of split-ball probe and tapered needle

Contact points standard-probes, hard chrome: c. 1000 HV

Thickness of chrome layer =

Size	0.50 - 1.50:	c. 8 $\mu\text{m}$
Size	1.75 - 3.75:	c. 10 $\mu\text{m}$
Size	4.00 - 9.50:	c. 20 $\mu\text{m}$
Size	10.00 - 40.00:	c. 25 $\mu\text{m}$

Contact points HM-plated probes: c. 1800 HV

Hardness of probe-body: 58-60 HRC

Hardness of needle taper (steel): 62-64 HRC

Hardness of needle taper (HM): c. 1600 HV

### Life of split-ball probes, tapered needles and rings

Important for the life are the wear conditions during the measuring operation and the measuring pressure. With a clean bore and non abrasive material it is possible to take several 100.000 measurements with a hard-chromed probe.

In case of unfavourable wear conditions, dirty bores, floating particles (emery etc.) in the bore and in case of very large quantities HM-probes and HM-needles should be used.

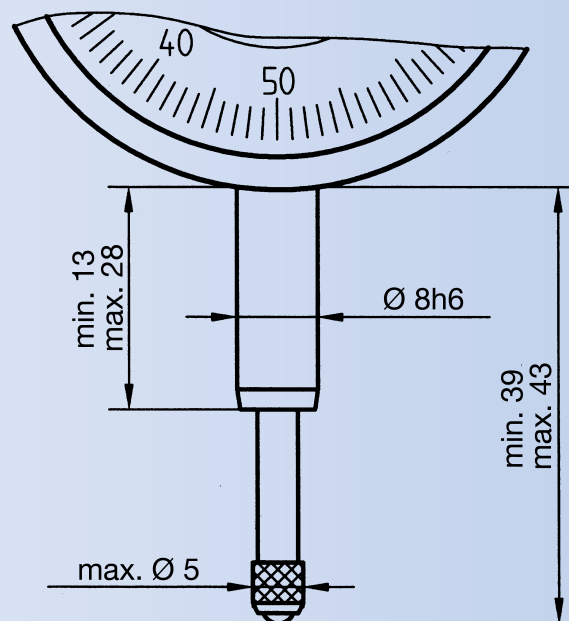


Fig. 8



# ADJUSTING OF DIATEST SPLIT-BALL PROBES

Fig. 9 correct

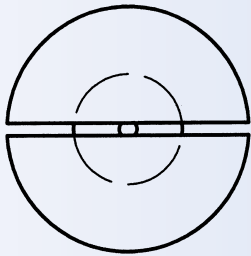


Fig. 10 wrong

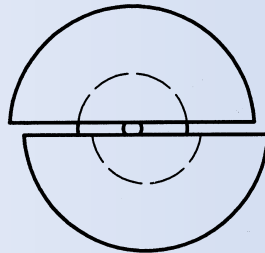


Fig. 11 adjusting

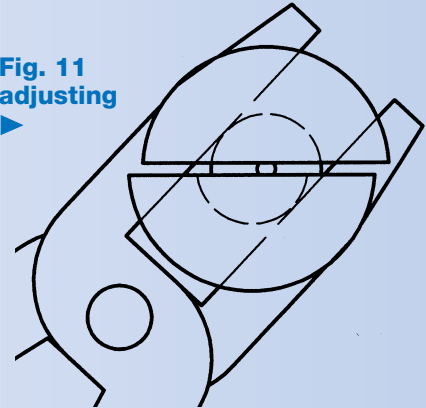


Fig. 12 correct

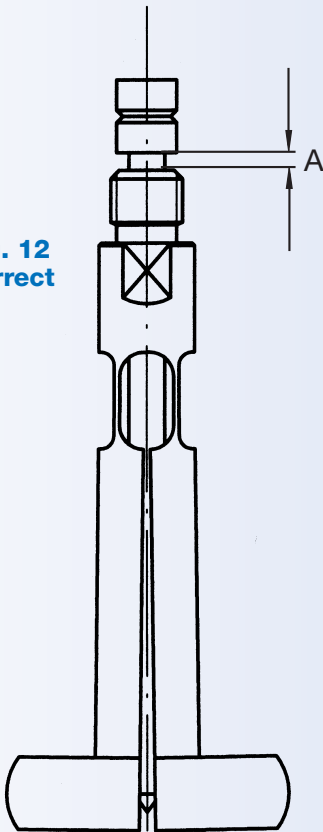


Fig. 13 wrong

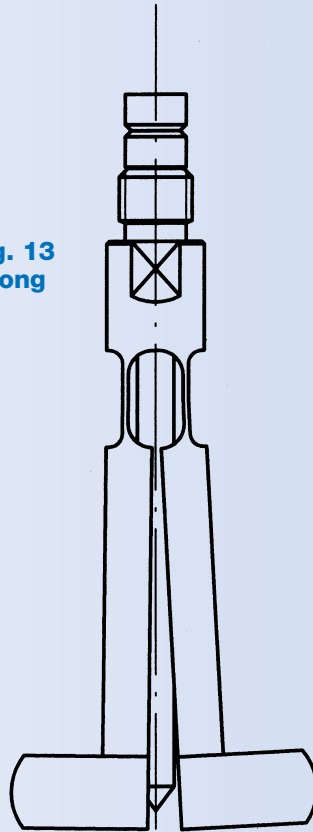


Fig. 14 wrong

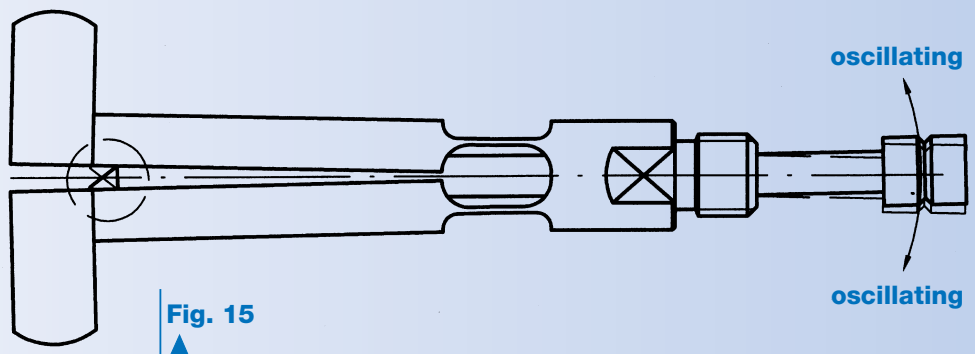
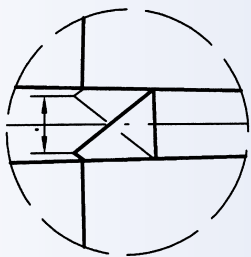
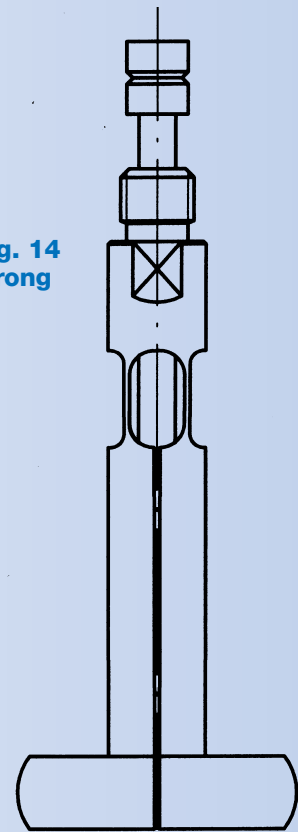


Fig. 15

**Jean-Louis MENEGON**

Représentant & conseiller Sud Ouest

tél: 06.76.08.96.83 - mail: [jlouismenegon@aol.com](mailto:jlouismenegon@aol.com) - site web: [www.menegon-metrologie.com](http://www.menegon-metrologie.com)

**MAINTENANCE / BENDING TEST / REPAIR OF PROBES****Maintenance of probes and needles**

should be made with the necessary care - like with all gauges. Special maintenance is not required. If the probes become heavily fouled clean them with a cleansing agent. Then protect the gauges against rust (slightly lubricating, store them in a dry place). **Important:** Lubricate the taper of the needle from time to time with grease (e.g. Vaseline).

**Setting rings**

1.750 to 40.000 mm

will be protected against rust by greasing or lubricating the bore (Vaseline).

**Setting rings**

0.500 to 1.500 mm

have a bore made of synthetic sapphire and thus are noncorrosive.

**Dial Indicators**

**Important:**  
**flexible shaft - never grease or lubricate!**

**Repair of split-ball probes**

DIATEST split-ball probes are largely damage-proof when being treated appropriately. Careless treatment may lead to bending of a probe. From size 1.75 the repair works can be made by yourself as follows:

**1. Radial bending (Fig. 9 - 11)**

**Testing:** press probe slightly together. The semicircular measuring jaws will obviously have to be symmetrical (Fig. 9).

**Adjusting:** When a probe is radially bent (Fig. 10) briefly bend with flat pliers directly behind probe-head to other direction (slightly beyond central point because of resilience, Fig.11).

**2. Axial bending: (Fig. 12 - 15)**

a) Distance "A" (Fig.12) of probe-head to probe-threading should be as follows when needle is loosely introduced:

Size 1.75 - 3.75	c. 0.3 - 0.4 mm
Size 4.0 - 40. := (056)	c. 0.4 - 0.6 mm

b) Probe legs should obviously be symmetrical to probe axis. Fig. 12 and 15 = correct, Fig. 13 = wrong. Probe legs that are bent (Fig. 13) or bent together (Fig. 14) can be adjusted by careful bending of the legs. For this probe has to be held at threaded piece.

**Testing for axial bending**

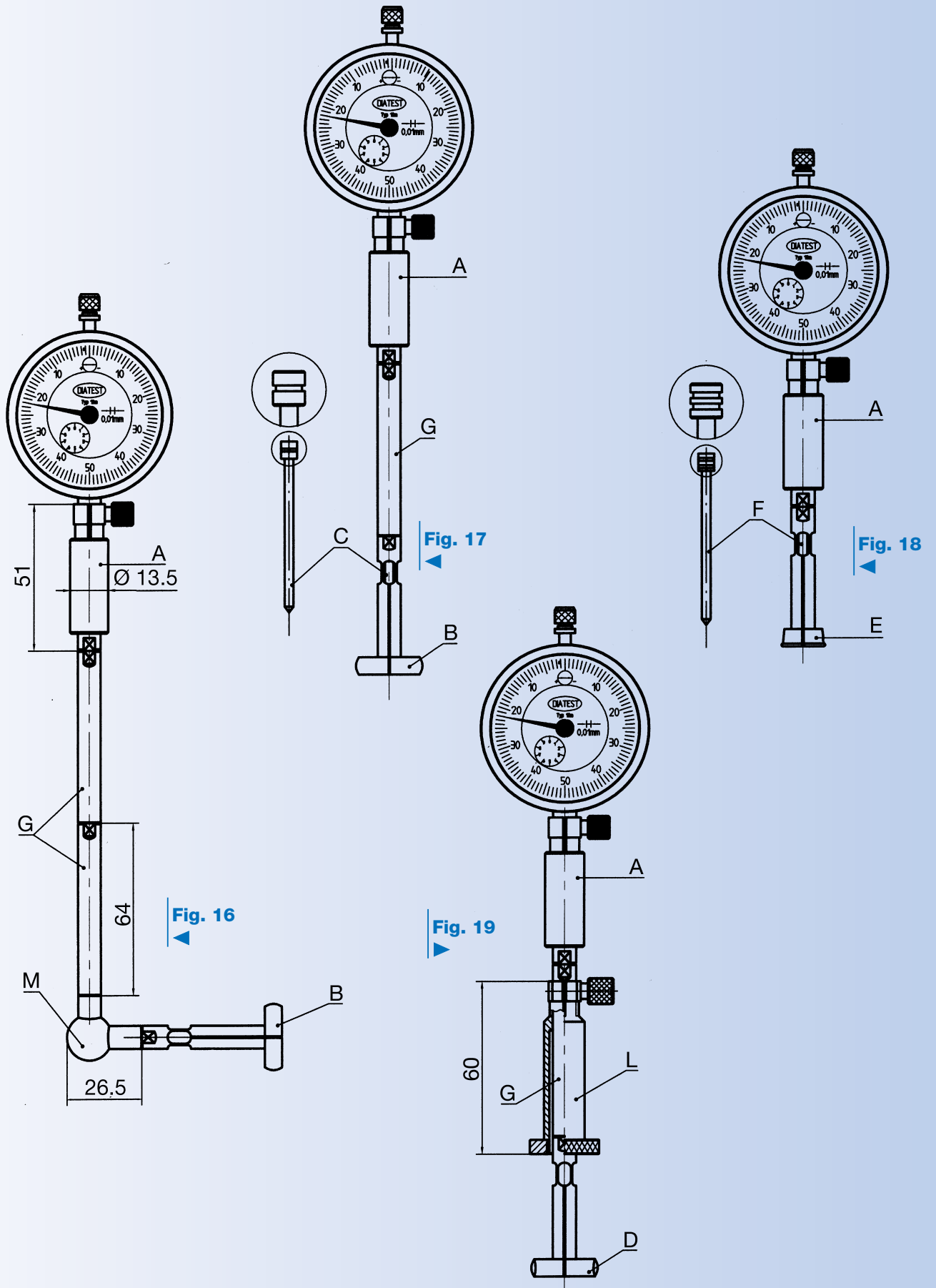
Hold probe at threaded piece - slot horizontal (Fig. 15). Introduce tapered needle by c. 3/4 into the bore of probe. Oscillate. In lower and upper position the taper of the needle should form about the same distances with the edges of the legs as explained in sector (Fig. 15).

**Jean-Louis MENEGON**

Représentant & conseiller Sud Ouest

tél: 06.76.08.96.83 - mail: [jlouismenegon@aol.com](mailto:jlouismenegon@aol.com) - site web: [www.menegon-metrologie.com](http://www.menegon-metrologie.com)

**DIATEST-SYSTEM**



**Jean-Louis MENEGON**

Représentant & conseiller Sud Ouest

tél: 06.76.08.96.83 - mail: [jlouismenegon@aol.com](mailto:jlouismenegon@aol.com) - site web: [www.menegon-metrologie.com](http://www.menegon-metrologie.com)

## DIATEST-SYSTEM

The standardized connection thread M 6 x 0.75 makes possible a varied combination of the individual gauging elements according to the measuring job.

### A. Standard indicator holder

Bore  $\varnothing$  8 H 7 (Order Code MH-6-51)

For connecting probes resp. other gauging elements and indicating unit.

#### Special accessories

Holder with location bore  $\varnothing$  3/8" = 9.525 mm (Order Code MH-6-51-Z), holder with length 32 mm (Order Code MH-6-32) and retracting indicator holder (Order Code MH-6-73-R).

### B. Standard split-ball probes

Measuring range 0.47 - 41.10 mm (Order Code T-\*)

Measuring surfaces hard chromed. Spherical shape of head which allows easy introduction into bore.

### C. Standard tapered needles

(Order Code N-\*)

Marking: 1 annular groove at needle head. For standard split-ball probes from 0.47 - 41.10 and HM-probes from 1.50 - 41.10 mm.

#### Standard HM-needle

Without illustration (Order Code NHM-\*)

Marking: 1 annular groove at black-finished needle head. For standard and HM - split-ball probes from 1.50 - 41.10 mm.

### D. HM Probes

Measuring range 1.50 - 41.10 mm (Order Code T-HM-\*)

Spherical measuring surfaces with carbide insert, size 1.75 - 4.00 plain carbide head. Not chromed, otherwise like standard

probes (B). Specially suitable for serial measurements and for measuring of bores in heavily worn or contaminated bores. Life of a HM probe often comes to 10 - 100 times of a standard probe. Not suitable for measuring of bores in copper, nickel and unalloyed aluminum. Here use standard probes, unless bores are heavily contaminated.

### E. Flat Bottom Probes

Measuring range 1.50 - 41.10 mm (Order Code T-FB-\*)

Measuring surfaces hard chrome plated, contact points lowered, therefore measurements close to bottom of bore possible. (See table page 16/17, measuring height H2)

### F. Flat Bottom Needle

(Order Code NFB-\*)

Identification: 2 annular grooves at needle head. For flat bottom probes 1.50 - 41.10 mm

#### Flat Bottom-HM Needle

(Order Code NFB-HM-\*) without illustration

Identification: 2 annular grooves at needle head.

For flat bottom probes 1.50 - 41.10 mm

### G. Standard Extension

$\varnothing$  8 x 64 mm (Order Code TV-8-64)

For measuring of deeper bores from c.  $\varnothing$  8.3 mm. Combination of several extensions is possible. Available in same version are extensions L = 20, 30, 40, 50, 80, 100, 125, 250, 500, 750 and 1000 mm. From L = 80: Temperature stabilized.

\* Add size to order code, see DIATEST price list

## DIATEST-SYSTEM

### H. T Probes

Measuring range 2.05 - 9.80 mm  
(Order Code T-T-\*)

For measuring deeper bores. Only suitable together with T-Extensions (J) .  
Combination of extension is not possible.

### J. T Extensions

For T probes 2.05 - 9.80 mm  
(Order Code TV-\*)

Extension-Ø 2.0, 2.5 and 4.0 mm. Lengths 64, 125, 250, 500 and 750 mm.  
Combination of extension is not possible.

### K. T Needles

(Order Code NT-\*)

Identification: Head without grooves.  
For T probes 2.05 - 9.80 mm. Order code NT-HM-\*. Identification: Black finished head without groove

### L. Depth Stop

(Page 12, Fig. 19)  
(Order Code TA-8-\*)

Makes possible gauging in defined bore depth, e.g. with internal taper, counter bores, narrow bore paths etc.  
Oscillating of bore gauge not necessary because Stopp ring (24 mm Ø) guards the vertical of bore gauge inside bore.  
Also very helpful for measuring small, light parts. Depth stop is clamped to a standard extension (G).

### Special Accessories

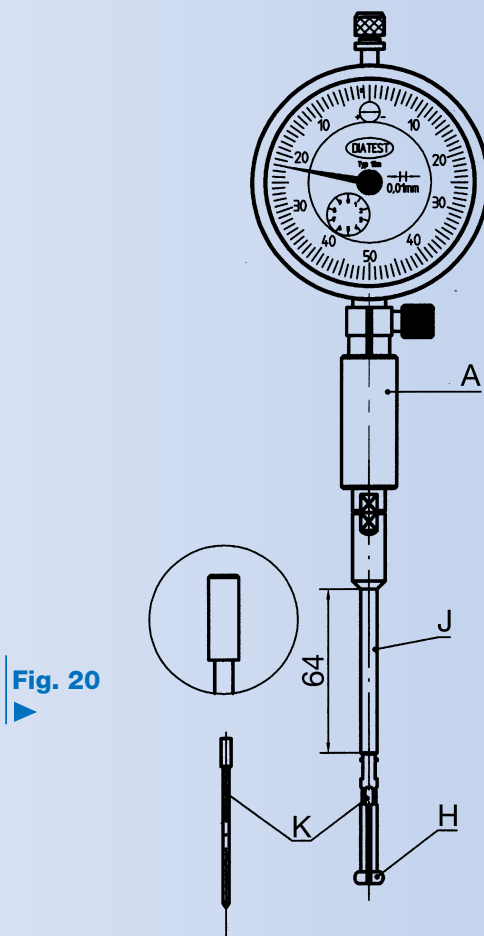
Screwable caps with stop-Ø 45 and 60 mm (without illustration).  
(Order Code TA-8-AS-\*)

### M. Right Angle Attachment

(Page 12, Fig. 16)  
(Order Code W-6)

Is inserted between holder and probe when limited space, e.g. when measuring at internal grinding machines, drilling and turning machines etc. Consequently a work-piece often can be measured without unclamping. The min. distance between work-piece and obstacle is: 27 mm plus probe length "L", see table page 16/17.

\* Add size to order code, see DIATEST price list



## DIATEST-SYSTEM

### N. 3-Point Probes

(Order Code T-3-P-\*)

Measuring range: 4.75 - 150.6 mm

#### Flat Bottom Version

4.75 - 150.6 mm on request

3-point probes are used in checking stands, fixtures and measuring machines. Hand measurements are difficult to perform.

#### Operational areas

1. Measuring of large bore- $\emptyset$
2. Measuring of polygonal bores, e.g. due to clamping pressure deformed, thin-walled work-pieces.

### O. 3-Point Needles

Without illustration (Order Code N-3-P-\*)

Identification: 3 annular grooves at needle head. For 3-point probes 4.75 - 160.6 mm.

#### HM-3-Point Needle

Without illustration (Order Code N-3-P-HM-\*)

For measuring range 4.75 - 160.6 mm. Identification: 3 annular grooves at needle head, black finished head. Without illustration, 3-point needle for 3-point flat bottom probe (special accessory).

### P. Gun Barrel Probes

Measuring range 2.8 - 41.10 mm

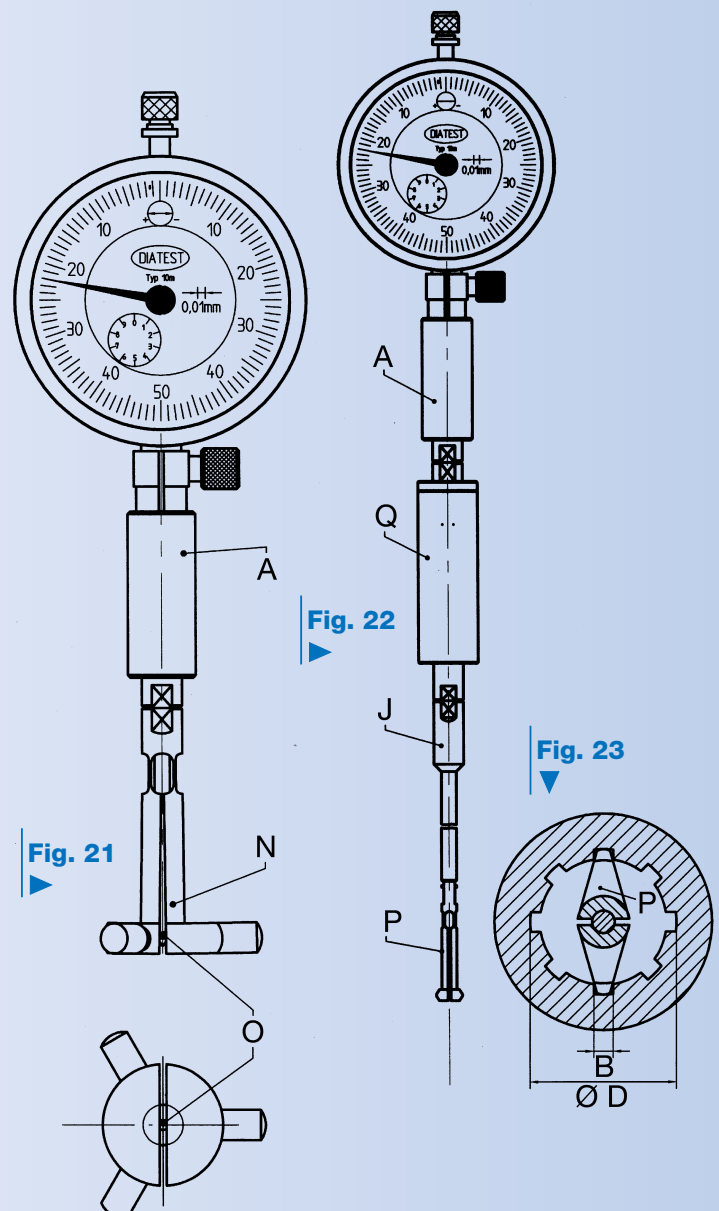
To measure the groove- $\emptyset$  of twisted grooved tubes, like e.g. gun barrels. Measuring range of probes: Corresponding to T- or standard probes (see table page 16-18). Use T- or standard needles. In connection with T- or standard extensions: Measuring depths till 1000 mm.

### Q. Rotary Adaptor

(Order Code TV-64-D)

Adaptor is screwed between holder and extension for gun barrel probes. The probe follows the twist, while the indicator remains stationary. Specially suitable for **roundness measurements** of work-pieces which cannot be turned on stands and gauging fixtures.

\* Add size to order code, see DIATEST price list



**Jean-Louis MENEGON**

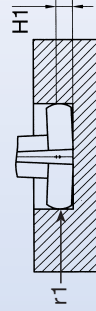
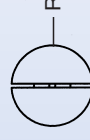
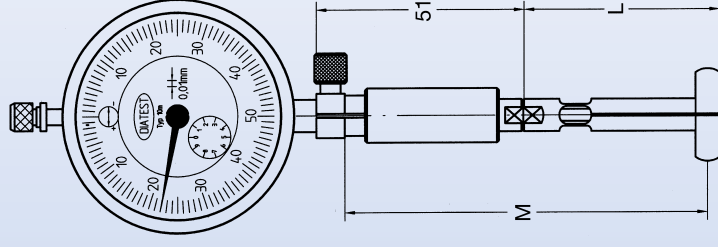
Représentant & conseiller Sud Ouest

tél: 06.76.08.96.83 - mail: [jlouismenegon@aol.com](mailto:jlouismenegon@aol.com) - site web: [www.menegon-metrologie.com](http://www.menegon-metrologie.com)

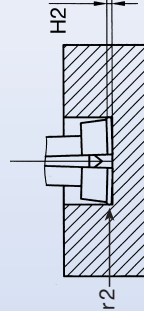
**DIATEST SMALL BORE GAUGES, STANDARD, FOR BORE HOLE Ø 0.47 MM TO 41.1 MM.**

Range mm	Standard probes Hard chrome plated*		Blind bore probes Hard chrome plated		Technical information							
	Single	Set	Single	Set	Length of probes	Max. measuring depth	Radius of contacts		Radius of contacts		Min. measuring height	Measuring pressure of dial gauge
	Order Code	Order Code	Order Code	Order Code			Standard probe	R	Standard probe	Blind bore probe		
0.47 - 0.53	T-0.50	N00-030			19,5	1,5	0,21	0,25	0,25	0,25	0,25	N (c.)
0.52 - 0.58	T-0.55											
0.57 - 0.67	T-0.60	N00-040										
0.75 - 0.87	T-0.80											
0.85 - 0.97	T-0.90			19,5	11	0,46	0,50	0,50	0,6	0,6	0,3 - 0,6	
0.95 - 1.15	T-1.0	N0-070 (NHMG-070)										
1.07 - 1.25	T-1.1											
1.17 - 1.35	T-1.2											
1.27 - 1.45	T-1.3			25,3	17	0,70	0,65	0,65	0,9	0,9	0,5 - 0,8	
1.37 - 1.55	T-1.4											
1.50 - 1.90	T-2.00	N1-100 (NHM1-100)	T-FB-1.75									
1.80 - 2.20	T-2.25		T-FB-2.00									
2.05 - 2.45	T-2.50		T-FB-2.25	30,6	22	1,10	0,85	0,85	1,2	1,2	0,8 - 1	
2.30 - 2.70	T-2.75		T-FB-2.50									
2.55 - 2.95	T-3.00		T-FB-2.75									
2.85 - 3.25	T-3.25		T-FB-3.00									
3.05 - 3.45	T-3.50		T-FB-3.25	47,3	40	2,75	2,00	2,00	2	2	1,2 - 1,8	
3.30 - 3.70	T-3.75		T-FB-3.50									
3.55 - 3.95	T-3.75		T-FB-3.75									
3.80 - 4.20	T-4.00/1		T-FB-4.00/1									
3.70 - 4.30	T-4.0			48,5	50	4,60	4,00	4,00	3,3	3,3	1,5 - 2	
4.20 - 4.80	T-4.5		T-FB-4.5									
4.70 - 5.30	T-5.0		T-FB-5.0									
5.20 - 5.80	T-5.5		T-FB-5.5									
5.70 - 6.30	T-6.0		T-FB-6.0	M2-FB	50	4,25	2,75	2,75	5,00	5,00	1,5 - 2,5	
6.20 - 6.80	T-6.5		T-FB-6.5									
6.70 - 7.30	T-7.0		T-FB-7.0									
7.20 - 7.80	T-7.5		T-FB-7.5									
7.70 - 8.30	T-8.0		T-FB-8.0	M3-FB	90	8,10	5,00	5,00	8,10	8,10	1,5 - 2,5	
8.20 - 8.80	T-8.5		T-FB-8.5									
8.70 - 9.30	T-9.0		T-FB-9.0									
9.20 - 9.80	T-9.5		T-FB-9.5									
9.70 - 10.30	T-10.0/2		T-FB-10.0/2	M4-FB	90	10,1	5,00	5,00	10,1	10,1	1,5 - 2,5	
10.40 - 10.60	T-11		T-FB-11									
11.40 - 11.60	T-12		T-FB-12									
12.40 - 12.60	T-13		T-FB-13									
13.40 - 13.60	T-14		T-FB-14	M5-FB	100	15,3	5,00	5,00	15,3	15,3	1,5 - 2,5	
14.40 - 14.60	T-15		T-FB-15									
15.40 - 15.60	T-16		T-FB-16									
16.40 - 16.60	T-17		T-FB-17									
17.40 - 17.60	T-18		T-FB-18	M5-FB	100	16,3	5,00	5,00	16,3	16,3	1,5 - 2,5	
18.40 - 18.60	T-19		T-FB-19									
19.40 - 19.60	T-20		T-FB-20									
20.40 - 20.60	T-21		T-FB-21									
21.40 - 21.60	T-22		T-FB-22	M4-FB	90	11,1	5,00	5,00	11,1	11,1	1,5 - 2,5	
22.40 - 22.60	T-23		T-FB-23									
23.40 - 23.60	T-24		T-FB-24									
24.40 - 24.60	T-25		T-FB-25									
25.40 - 25.60	T-26		T-FB-26	M5-FB	100	12,6	5,00	5,00	12,6	12,6	1,5 - 2,5	
26.40 - 26.60	T-27		T-FB-27									
27.40 - 27.60	T-28		T-FB-28									
28.40 - 28.60	T-29		T-FB-29									
29.40 - 29.60	T-30		T-FB-30	M5-FB	100	13,1	5,00	5,00	13,1	13,1	1,5 - 2,5	
30.40 - 30.60	T-31		T-FB-31									
31.40 - 31.60	T-32		T-FB-32									
32.40 - 32.60	T-33		T-FB-33									
33.40 - 33.60	T-34		T-FB-34	M5-FB	100	14,1	5,00	5,00	14,1	14,1	1,5 - 2,5	
34.40 - 34.60	T-35		T-FB-35									
35.40 - 35.60	T-36		T-FB-36									
36.40 - 36.60	T-37		T-FB-37									
37.40 - 37.60	T-38		T-FB-38	M5-FB	100	14,6	5,00	5,00	14,6	14,6	1,5 - 2,5	
38.40 - 38.60	T-39		T-FB-39									
39.40 - 39.60	T-40		T-FB-40									
40.40 - 40.60	T-41		T-FB-41									
28.90 - 31,10	T-30/5		T-FB-30/5									
30.90 - 33,10	T-32		T-FB-32									
32.90 - 35,10	T-34		T-FB-34									
34.90 - 37,10	T-36		T-FB-36									
36.90 - 39,10	T-38		T-FB-38									
38.90 - 41,10	T-40		T-FB-40									

\* Standard probes are also available in style T-HM (carbide inserted) from Ø 1,5; T-KE (ceramic inserted) from Ø 3,7.



Standard probe



Blind bore probe

Fig. 24

**Maximum measuring depth M**

Depends on probe size. For determination of max. measuring depth. Insert bore gauge partly into bore up to indicator.

Larger measuring depths from: Ø 8.20 mm with extension Ø 2.05 mm with T-probes Ø 0.95 mm with special probes

**Length of probes L**

When space is limited and right angle attachment is used, minimum distance between bore obstruction = 27 mm + length of probes (L).

**Minimum measuring height H**

Indicates how close to bore ground can be gauged when probe is spread to maximum.



## DIATEST T-PROBES TO MEASURE DEEPER BORES; FOR BORE HOLE Ø 2.05 TO 9.80 MM.

Range mm	Standard probes Hard chrome plated*)		Technical informations				
	Single Order Code	Set Order Code	Standard needle Steel (Carbide) Order Code	Length of probes L	Thread of T-probes	Max. measuring depth (T-extension 64 mm) M	Required T-extension
2,05 – 2,45 2,30 – 2,70	T-T-2,25 T-T-2,50		NT1-100 NT-HM1-100	25,3	M1,7 X 0,25	90	TV-2
2,55 – 2,95 2,80 – 3,20 3,05 – 3,45 3,30 – 3,70 3,55 – 3,95 3,80 – 4,20	T-T-2,75 T-T-3,00 T-T-3,25 T-T-3,50 T-T-3,75 T-T-4,00	M1-T	NT1-150 (NT-HM1-150)	30,6	M2,3 x 0,25	95	TV-2,5
4,20 – 4,80 4,70 – 5,30 5,20 – 5,80 5,70 – 6,30 6,20 – 6,80 6,70 – 7,30 7,20 – 7,80 7,70 – 8,30 8,20 – 8,80 8,70 – 9,30 9,20 – 9,80	T-T-5,50 T-T-5,00 T-T-5,50 T-T-6,00 T-T-6,50 T-T-7,00 T-T-7,50 T-T-8,00 T-T-8,50 T-T-9,00 T-T-9,50	M2-T	NT2-150 (NT-HM2-150)	31,0	M3,5 x 0,35	95	TV-4

\* Max depth M for T-probes: T-probe with T-extension 64 mm. For deeper bores with longer extensions.  
From Ø 2,55 T-probes are also in style T-T-HM (carbide inserted) available.

Range mm	Technical informations			
	Radius of contacts		Min. measuring height Standard probe	Measuring pressure of dial gauge
	R	Standard probe r1	H1	N(c.)
2,05 – 2,45 2,30 – 2,70	0,97 1,07	0,65	0,9	0,8-1,0
2,55 – 2,95 2,80 – 3,20 3,05 – 3,45 3,30 – 3,70 3,55 – 3,95 3,80 – 4,20	1,20 1,28 1,45 1,57 1,63 1,82	0,95	1,2	0,8-1,0
4,20 – 4,80 4,70 – 5,30 5,20 – 5,80 5,70 – 6,30 6,20 – 6,80 6,70 – 7,30 7,20 – 7,80 7,70 – 8,30 8,20 – 8,80 8,70 – 9,30 9,20 – 9,80	2,02 2,27 2,52 2,77 3,02 3,27 3,52 3,77 4,02 4,27 4,52	1,75	1,7	1,0-1,5

**Jean-Louis MENEGON**

Représentant & conseiller Sud Ouest

tél: 06.76.08.96.83 - mail: [jlouismenegon@aol.com](mailto:jlouismenegon@aol.com) - site web: [www.menegon-metrologie.com](http://www.menegon-metrologie.com)

## DIATEST CHECKING STANDS

Stands offer in connection with DIATEST split-ball probe sets the safe basis for fast and accurate accomplishing measuring jobs ( $\emptyset$ -measuring, measuring of bell mouth, conical form, roundness etc.). Specially beneficial is the use of stands directly on the working place for bore control during production, on vendor inspection department, on final inspection and also in the measuring room.

Accessories like floating holder, vee attachments and others make it possible to solve numerous measuring jobs. These measuring jobs can then be reliably performed also by untrained workers.

DIATEST checking stands are easy to install and to adjust depending on the measuring job.

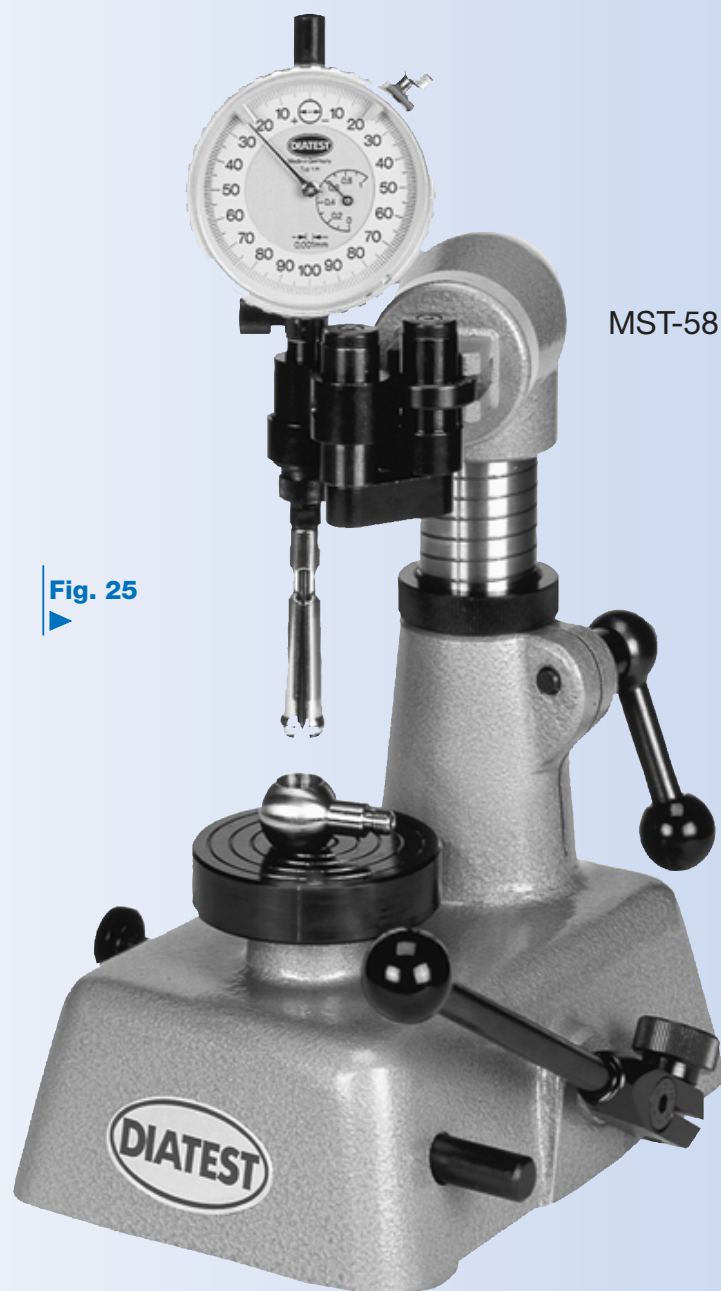


Fig. 25

**Jean-Louis MENEGON**

Représentant & conseiller Sud Ouest

tél: 06.76.08.96.83 - mail: [jlouismenegon@aol.com](mailto:jlouismenegon@aol.com) - site web: [www.menegon-metrologie.com](http://www.menegon-metrologie.com)

**DIATEST PRECISION CHECKING STAND MST-58****DIATEST Precision Checking Stand (Fig. 26)**

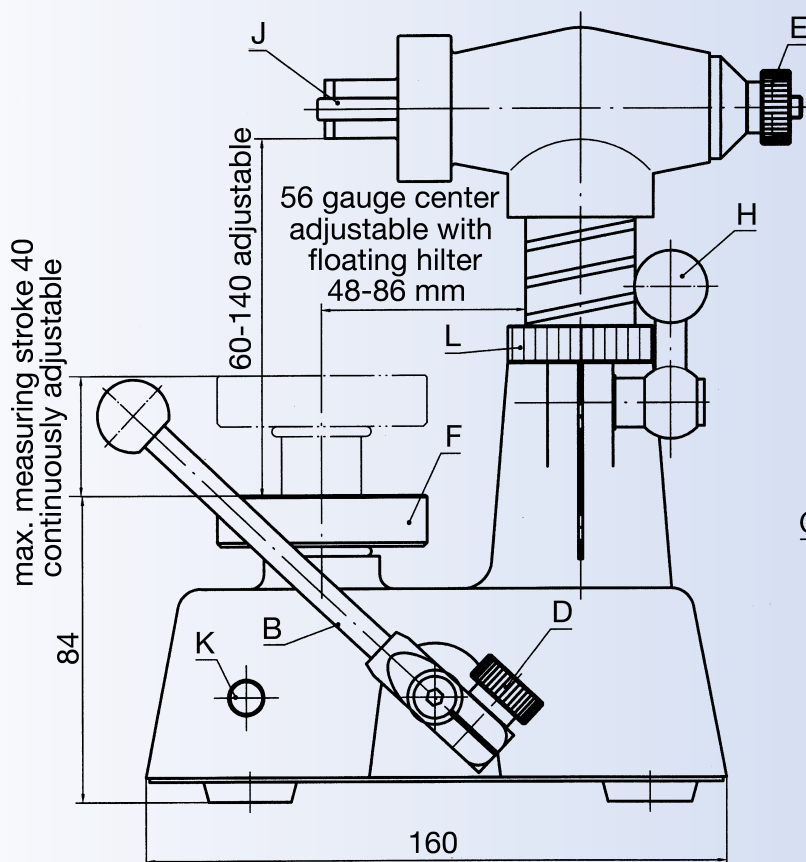
(Order code MST-58)

Specially easy to operate. For light work-pieces like ball bearing rings, nozzles, bushings and other small parts.

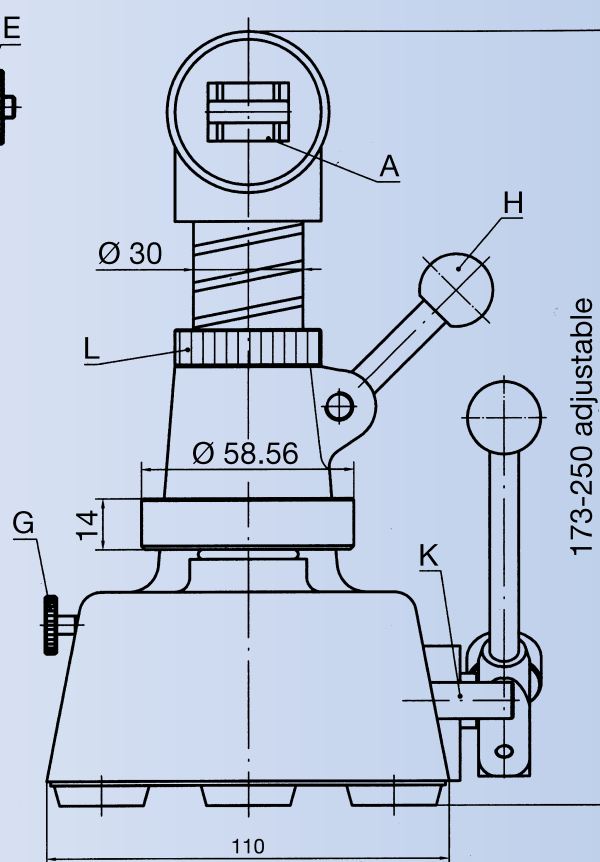
**A. Top of Stand with clamping prism**

The bore gauge (floating holder or standard dial gauge holder with corresponding probe and indicating unit) is clamped by a knurled nut (E) over a connection rod into clamping prism.

**Fig. 26 a**  
Precision checking stand, MST-58



**Fig. 26 b**  
Precision checking stand, MST-58

**Jean-Louis MENEGON**

Représentant &amp; conseiller Sud Ouest

tél: 06.76.08.96.83 - mail: [jlouismenegon@aol.com](mailto:jlouismenegon@aol.com) - site web: [www.menegon-metrologie.com](http://www.menegon-metrologie.com)

**DIATEST PRECISION CHECKING STAND MST-58****B. Measuring Stroke Lever**

With the measuring stroke lever it is possible to sensitively lift the platen  $\varnothing 58.75$ . The stop pin (K) ends the measuring stroke. By adjusting of the measuring stroke lever (loose clamp D) measuring stroke is continuously adjustable from 0 to 40 mm.

**F. Platen**

$\varnothing 58.75$

Hardened and finish ground, black finished. Interchangeable fastened with threaded bolt M 6 on column  $\varnothing 22$  mm.

**G. Stop screw**

To lock the measuring stroke at any position.

**H. Column clamp lever**

The column of  $\varnothing 30$  with top of stand is continuously adjustable to a height of 80 mm. It is clamped by means of the column clamp lever.

**L. Knurling wheel**

For precisely adjusting height of upper part of stand.

**Special Accessories****Floating Holder**

(see page 24)

**Clamp-On-Vee (Fig. 27)**

for  $\varnothing 58.75$  mm  
(Order code MST-WA-58)

Is clamped to the platen  $\varnothing 58.75$ . The universal, adjustable stop prism makes possible a quick location of work-pieces symmetrical to the bore. Also other suitable gauging fixtures can be mounted to the stop collar.

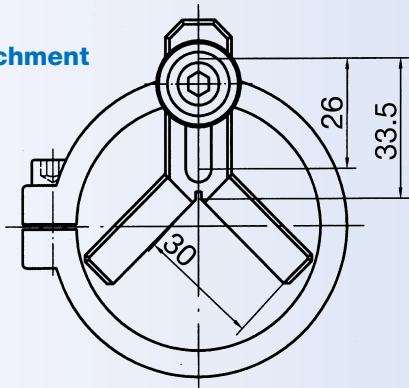
**Perforated Platen (Fig. 28)**

$\varnothing 80$  mm (Order Code MST-MT-80)

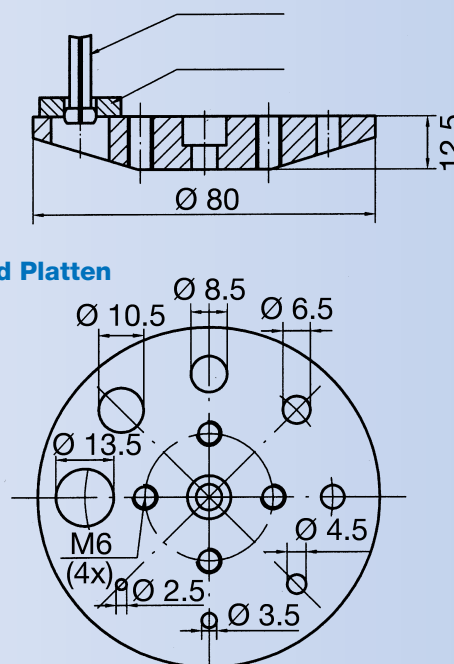
Mounted instead of platen  $\varnothing 58.75$  on column  $\varnothing 22$  by hexagon socket screw M6. The prism of clamping vee attachment or vee attachment of universal stand can be screwed on for locaton.

Specially suitable to measure through bores of flat work-pieces. Here the probe (till 13 mm  $\varnothing$ ) can engage the whole bore without knocking against the platen. Also suitable for larger work-pieces.

**Fig. 27**  
**Vee attachment**



**Fig. 28**  
**Perforated Platten**



**Jean-Louis MENEGON**

Représentant & conseiller Sud Ouest

tél: 06.76.08.96.83 - mail: [jlouismenegon@aol.com](mailto:jlouismenegon@aol.com) - site web: [www.menegon-metrologie.com](http://www.menegon-metrologie.com)

**DIATEST-UNIVERSAL STAND MST-102****DIATEST-Universal stand**

(Order code MST-102)

Especially suitable for gauging deep bores to 125 mm depth, bores in large and complicated work-pieces and for special measuring jobs.

**A. Platen**

100 x 100 x 25 mm

Hardened, black finished and finished ground, T-groove. Screwed onto the foot

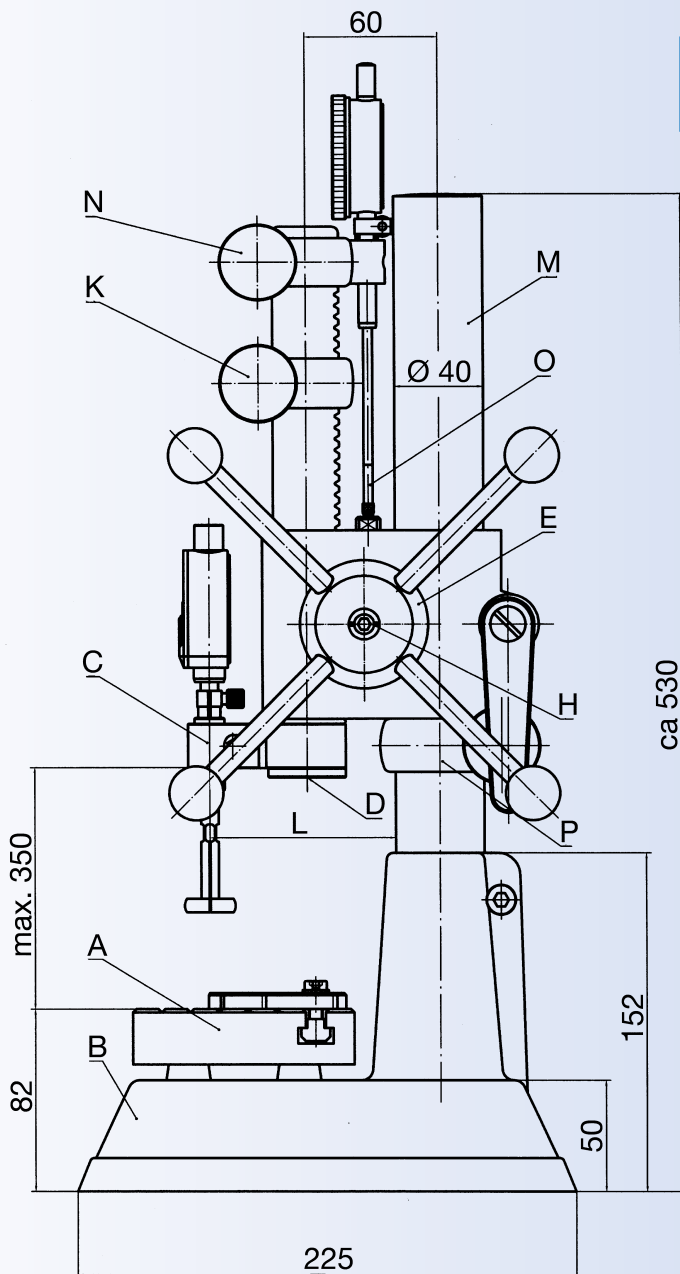
B of the stand with 3 interchangeable hexagon socket screws. The bolt-on-vee Q (standard accessory, Fig. 30), larger work-piece bodies, special pre-centering or auxiliary devices can be mounted on the platen (T-groove) or directly on the foot of the stand.

**Special accessories**

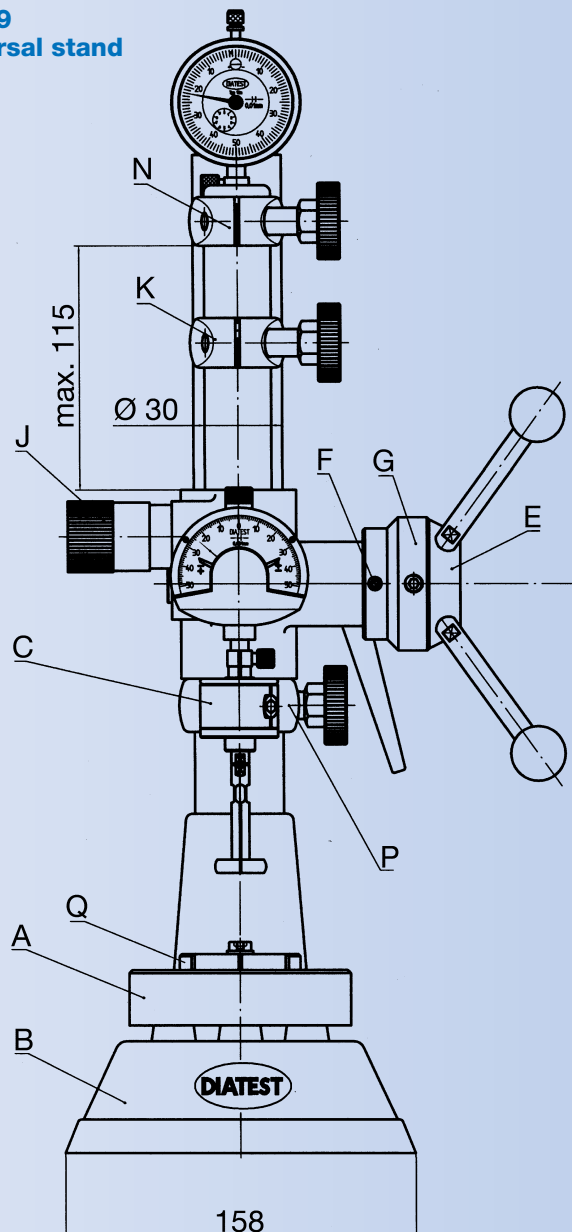
Order code MST-MT-\*

Platen dimension 130 x 100 and 160 x 100.

\* Add size to order code, see DIATEST price list



**Fig. 29**  
**Universal stand**

**Jean-Louis MENEGON**

Représentant &amp; conseiller Sud Ouest

tél: 06.76.08.96.83 - mail: [jlouismenegon@aol.com](mailto:jlouismenegon@aol.com) - site web: [www.menegon-metrologie.com](http://www.menegon-metrologie.com)

**DIATEST-UNIVERSAL STAND MST-102****C. Jib arm**

The gauge (floating holder or standard holder with corresponding probe and display unit) is clamped by means of a hexagon socket screw in the locating hole 13.5. The jib arm is slewably screwed on the support 30 with hexagon socket screw D. Distance „L“ from the middle of the gauge to the support 40 = 84 mm.

**When using the floating holder**

Distance „L“ adjustable from 20 to 110 mm. Work-pieces to a max. Ø resp. width of 200 mm can be fitted.

**Special accessories**

(Order code MST-AA-\*)

Jib arms, max. distance „L“ with floating holder = 150 or 200 mm. Platens with special dimensions.

**E. Star wheel handle**

The measuring stroke of 130 mm is achieved by turning the star wheel. The reversing stroke is effected by spring force. By means of detaching three screws F the spring tension ring G can be adjusted and thus the spring force can be changed. The star wheel itself can be brought into a different position by detaching screw H.

**J. Fixed knurled knob**

For locking the measuring stroke at any position.

**K. Collar**

Ø 30 mm

Limits the measuring stroke downwards. Continuously adjustable from 0 - 130 mm.

**M. Column**

Ø 40 mm

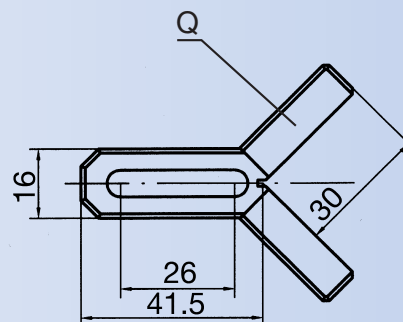
Can be exchanged for a longer column on request.

**Special accessories****N. Clamping ring**

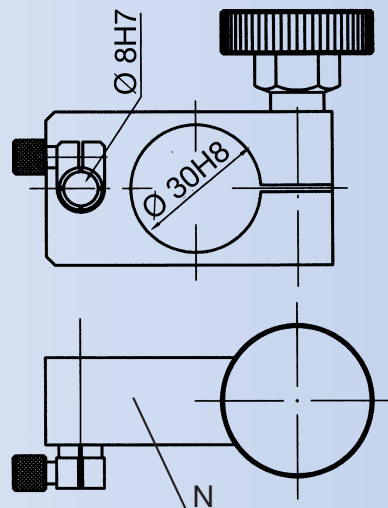
30 mm with dial gauge bracket  
(Order Code MST-KR-30)

When using dial gauges with large indicator range (e. g. DIATEST-dial gauge G-100-50 or G-100-80) the measuring stroke can be displayed according to size. The dial gauge is clamped in a bore 8 H7 by means of a knurled screw. The clamping ring is continuously adjustable on the support 30. On request the dial gauge can be extended through an additional dial gauge extension O. Available in 10 mm steps from 10 till 100 mm. Order Code MUZ-\*

\* Add size to order code, see DIATEST price list



**Fig. 30**  
Bolt-on-vee



**Fig. 31**  
Clamping ring

**Jean-Louis MENEGON**

Représentant & conseiller Sud Ouest

tél: 06.76.08.96.83 - mail: [jlouismenegon@aol.com](mailto:jlouismenegon@aol.com) - site web: [www.menegon-metrologie.com](http://www.menegon-metrologie.com)

---

## DIATEST-UNIVERSAL STAND MST-102

---

### O. Extension inserts

For dial indicator, thread M2,5  
(Order Code MUZ-...)

### P. Stop Collar

Ø 40 mm (Order Code MST-KR-40)

Continuously adjustable on column  
40 mm. Facilitates the setting of the  
stand.

### Q. Bolt-on-vee

(Order Code MST-WA)

---

## DIATEST-FLOATING HOLDER SH-T

---

### DIATEST-Floating holder

(Order code SH-T)

The DIATEST-floating holder is a **very important accessory** for DIATEST-bore gauges. It is especially suitable for serial measurements with high precision requirements. Especially for probes of sizes 00 and 0.

For stationary measurements with checking stands small parts can be measured quite well with probes. In case of bigger parts the self-centering capability of a probe is not sufficient to pull the work-piece safely into the axis. Then there is the danger that instead of the diameter the „**CHORD**“ of the bore is measured and the displayed dimension is too small.

The floating holder enables the gauge clamped in the stand (measuring machine or fixtures) a slight „floating“ in horizontal plane. The probe easily finds the exact axis when dipping into the bore. The reproducibility of a floating holder bore measurement is c.0.5 m. Thus very exact and faultless measurements can be carried through by general workers having no special gauge training.

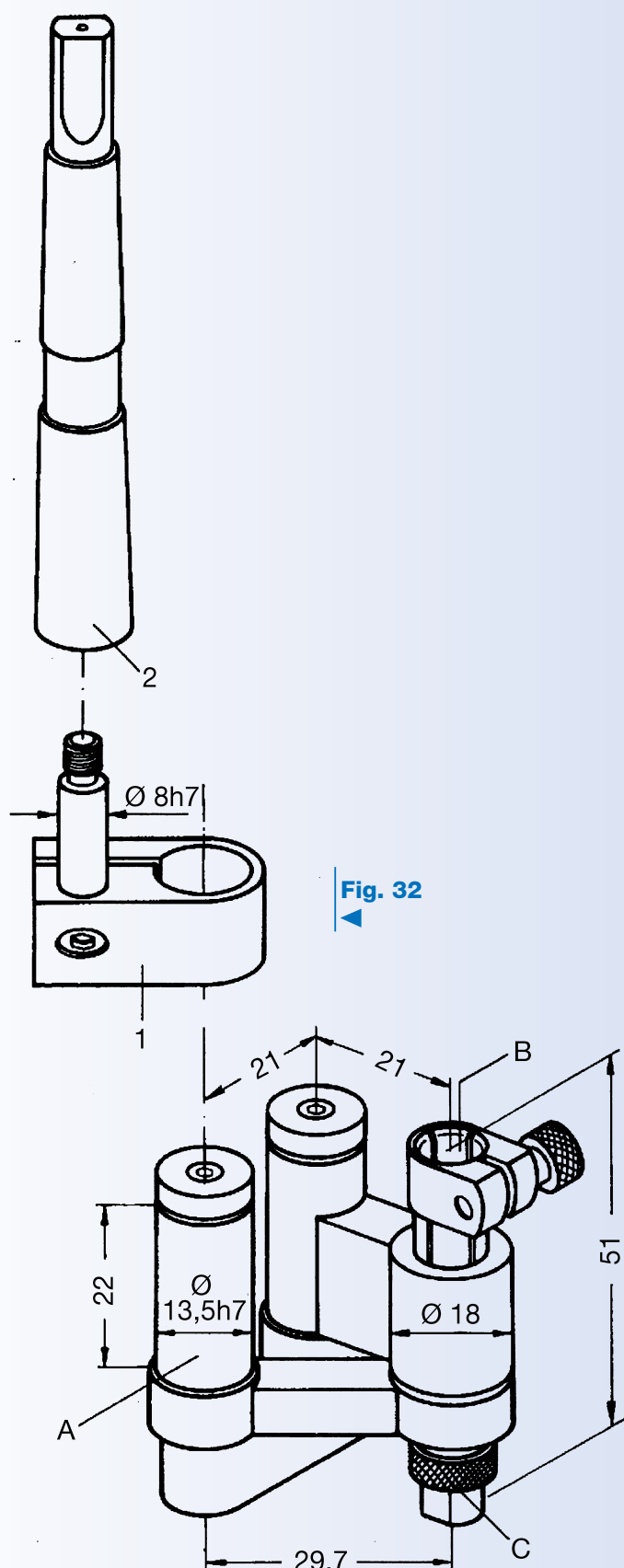
**DIATEST-FLOATING HOLDER SH-T**

Fig. 32

**Mode of operation**

Instead of the indicator holder the clamping shank 13.5 mm of the floating holder (A) is clamped onto the stand. Screw the probe into the locating thread M 6 x 0.75 and clamp the indicator onto the bore 8 H7 (B).

**Single measurements on stands**

The floating range is adjusted to the max. by taper-knurled nut (C). When dipping the probe into the bore please take into consideration that the measurement is made within the floating range (move the workpiece accordingly on the platen).

**Serial measurements on stands**

Adjust the floating range to zero by means of taper-knurled nut (C). Mount the suitable pre-centering for the work-piece (vee attachment, flat curved washer – a little bit smaller than the locating hole of the work-piece, special platen) so that the bore axis and the probe axis are nearly concentric. Then adjust the necessary floating range. Continuously adjustable floating range:

0-1.5 mm. Max. floating range (without regulation): 3 mm.

**Special accessories**

1. Shank adaptor  
(Order code SH-T-KS)

It is clamped onto the shaft 13,5 (A). For clamping the floating holder in drilling machines, measuring devices etc.

2. Morse taper MK 1  
(Order Code DZ-MK-1) acc. to DIN 228

Can be screwed on the shank adaptor, if required.

Remark: Floating holder also available with measuring pressure reducer.  
Order Code SH-T-F.

**Jean-Louis MENEGON**

Représentant & conseiller Sud Ouest

tél: 06.76.08.96.83 - mail: [jlouismenegon@aol.com](mailto:jlouismenegon@aol.com) - site web: [www.menegon-metrologie.com](http://www.menegon-metrologie.com)



## APPLICATIONS OF THE FLOATING HOLDER

### DIATEST precision Checking stand and Universal stand

Drilling machines, power tool drill stands and others. When there is not a stand available or in order to measure very deep bores you can use e. g. a drilling machine instead of a stand. Please secure the sleeve against turning, if necessary. Shank adaptor SH-T-KS is required.

### Measuring alignments, measuring machines

When e.g. measurements of external dimensions are taken at the same time also bore can be controlled with the floating holder and corresponding probes. The floating holder can be used being turned by 180° without losing its function.

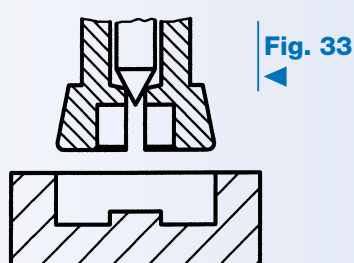
## FINALLY SOME ADVICE

### Important

When taking horizontal measurements with probes the slot of the probe also has to be horizontal! (contact points vertical – see page 4)

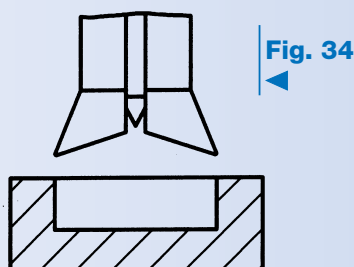
### Some special shapes of DIATEST bore gauges

Please send us drawings, work-pieces as well as description of the measurement process when inquiring.



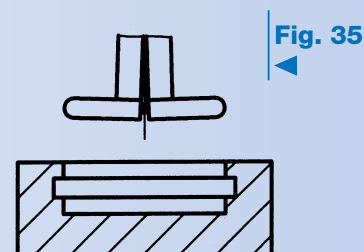
#### T-ZG

Measurement of bores with center stud, e. g. button of a watch, cartridge case.  
On request



#### Super-FB

Measurement of blind bores till c. 0.1 mm to the bottom of the bore.  
On request



#### Groove-probe

Special groove probe  
Measurement of the diameter of grooves.  
On request

**Jean-Louis MENEGON**

Représentant & conseiller Sud Ouest

tél: 06.76.08.96.83 - mail: [jlouismenegon@aol.com](mailto:jlouismenegon@aol.com) - site web: [www.menegon-metrologie.com](http://www.menegon-metrologie.com)

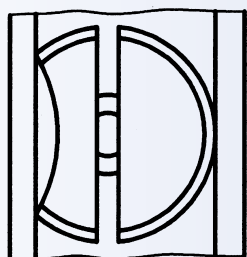
**FINALLY SOME ADVICE**

Fig. 36

**T-PA\***

Measurement of parallel distances, e.g. T-grooves, die clearances, cyl.-distances

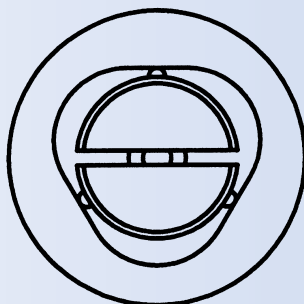


Fig. 37

**T-3P**

Measurement of polygon bores (bore-equidistant), from 4.7 mm Ø

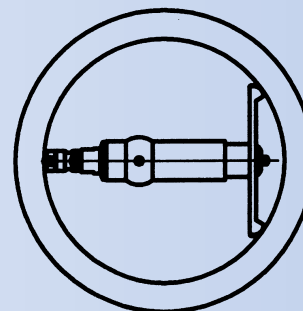


Fig. 38

Measurement of large bores from 19.5 - 330 mm  
DIATEST-gauge M5678

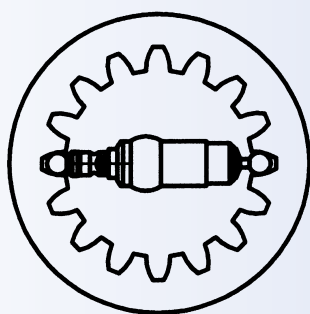


Fig. 39

Measurement of female threads from Mi 26 till c. 1000 mm.  
DIATEST-gauge ZM67

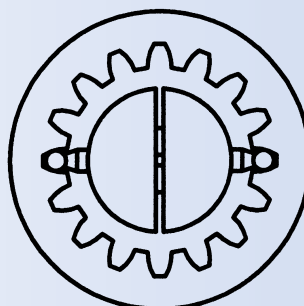


Fig. 40

Measurement of serrations, from MI 3.5 mm.  
DIATEST-gauges ZM23

For easy entry of the probe into the bore it is often better to limit the spreading of the probe to c. 0.1 - 0.2 mm over the max. bore diameter.

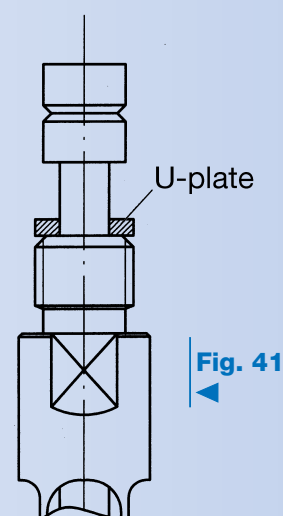


Fig. 41

\* Add size to order code, see DIATEST price list

**Jean-Louis MENEGON**

Représentant & conseiller Sud Ouest

tél: 06.76.08.96.83 - mail: [jlouismenegon@aol.com](mailto:jlouismenegon@aol.com) - site web: [www.menegon-metrologie.com](http://www.menegon-metrologie.com)

**QUALITÄT SERZEUGNISSE IN ALLE WELT**  
**QUALITY PRODUCTS SERVING THE WORLD**



**Jean Louis MENEGON**

Représentant et Conseiller  
Région Sud Ouest

**Tel : 06 76 08 96 83**

Email: [jlouismenegon@aol.com](mailto:jlouismenegon@aol.com)  
[www.menegon-metrologie.com](http://www.menegon-metrologie.com)

Visiter le site web :

[www.menegon-metrologie.com](http://www.menegon-metrologie.com)